

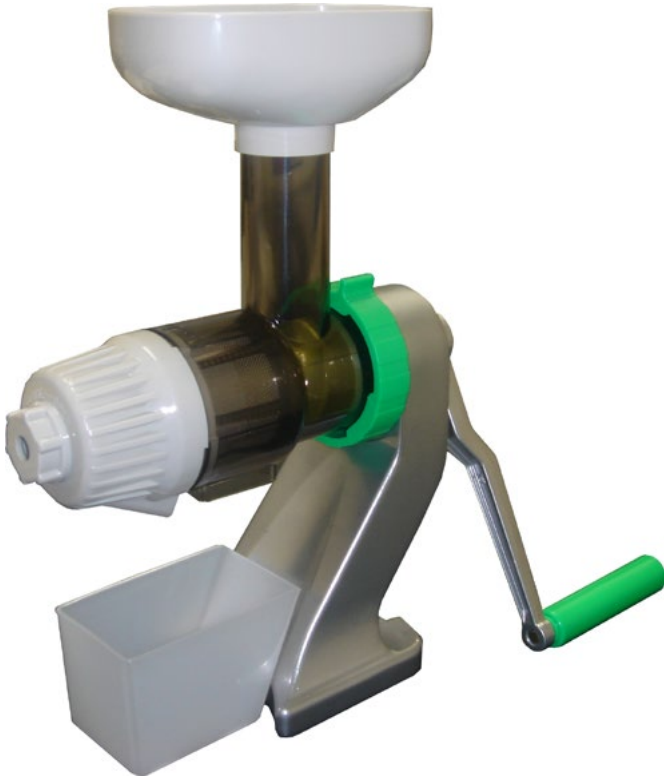

# INSTRUCTION MANUAL

Model: Z-610



**SAVE THIS MANUAL- KEEP IT HANDY FOR QUICK REFERENCE  
READ INSTRUCTIONS BEFORE USE**

# Table of contents

---

Important Safety Instructions -----	3
Warranty -----	4
Z-610 Manual Juicer Part Description -----	6
Z-610 Assembly and Operation -----	7
Disassembling the Z-610 -----	8
Cleaning the Z-610 -----	8
Trouble Shooting -----	9
When you need service -----	10
Warranty Registration Card -----	11
Product Specifications-----	13

©2012 Tribest Corp.

No copies, transmission, or translation into other languages of this manual by any means without written permission of Tribest Corp. is allowed. All rights are reserved.

---

## Important Safety Instructions

1. Please read all instructions carefully.
2. While the machine is in operation, avoid contact with its moving parts.
3. Close supervision is necessary when any appliances are used by or near children.
4. Do not put any articles such as spoons, forks or knives into the feeding chute.
5. It is very dangerous to place fingers into the feeding chute while it is in operation.  
Make sure to always use the provided plunger to push down materials.
6. Please refer to “When You Need Service” in case your juicer is functioning abnormally.
7. Do not disassemble any parts other than those necessary for normal operation or cleaning of your juice extractor
8. Do not use hot or boiling water (above 104°F or 40°C) to clean the unit and parts.  
Deformation or other damages may result.
9. Do not use any bleach or harsh chemicals.
10. This machine is made for household use only.
11. Please refer to the “INSTRUCTIONS” before use
12. Do not use the appliance for any other than its intended use.

**SAVE THESE INSTRUCTIONS**

# Warrenty

---

We warrant to you, the end-user customer who has properly registered after purchasing the Z-610 Juice Extractor for a valuable consideration, that the plastic juicing parts and metal clamp parts will be free from defects in materials and workmanship for a period of 1 year from the date of purchase. All other parts, including but not limited to the Juice Container and the Plastic Plunger are not subject to any warranty. Warranty does not cover normal wear and tear.

In order for you to receive the benefits of this warranty, you are required to complete and mail the warranty registration card (pg.11), containing all the requested information, to us within ten (10) days following the purchase of your Z-610 Manual Juicer.

1. No warranty will be provided until after we have actually received the enclosed warranty registration card, containing all the requested information, within ten (10) days of the date of original purchase. The warranty is only good for the original purchaser for value. This warranty is non-transferable.
2. If the Z-610 exhibits defects while in normal household use, we will, upon our actual receipt of a written notice of such defects from you during the warranty period, either repair or replace, at our option, the Z-610 that has verifiable manufacturing defects. However, we have no such obligation to repair or replace until after you have, by insured mail and in protective packaging\*, delivered the Z-610 to the location of your service center as set forth on page 10. Replacement Z-610 may be either new or like new. Z-610 may contain re-manufactured or re-conditioned parts, which are equivalent to the new in performance or may have been subject to incidental use.
3. We do not warrant that the operation of the Z-610 will be uninterrupted or error free. In no event shall our liability exceed the retail value of the Z-610.
4. All warranty and repair services must be performed at a warranty service center, which is located within the country where the machine was originally purchased. However, in the event that: [i] the machine must be serviced at a service center, which is not located within the country where the machine was purchased; or [ii] there is no service center within the country where the machine is located and must be shipped to a service center in another country, then those service centers are responsible for the parts and service only, and any and all costs relating to the shipping, delivery and handling of the machine to and from those service center shall be the sole responsibility of the owner.

This warranty does not cover defects resulting from: [a] failure to operate the Z-610 in accordance with the instructions; [b] use of parts or supplies not provided or authorized by us; [c] negligent, improper or inadequate maintenance; [d] service performed or attempted by unauthorized service person; [e] damages, accidental or otherwise to the Z-610, which are not directly caused by us or the manufacturer; or [f] damages resulting from abuse, tampering, misuse, commercial use, or unauthorized modification of the Z-610.

---

WE MAKE NO OTHER EXPRESS OR IMPLIED WARRANTY OR CONDITION WHETHER WRITTEN OR ORAL TO THE EXTENT ALLOWED BY LOCAL LAW, ANY IMPLIED WARRANTY OF FITNESS FOR A PARTICULAR PURPOSE OR IMPLIED WARRANTY OR CONDITION OF MERCHANTABILITY IS LIMITED TO ONE (1) YEAR. In the event that such limitation or exclusion on the duration of an implied warranty is not allowed in the state or county wherein you reside, the above limitation or exclusion will not apply. This warranty gives you specific legal rights and protection, and you might also have other rights that vary from state to state, or country to country.

TO THE EXTENT ALLOWED BY LOCAL LAW, THE REMEDIES IN THIS WARRANTY STATEMENT ARE YOUR SOLE AND EXCLUSIVE REMEDIES. EXCEPT AS INDICATED ABOVE, IN NO EVENT WILL WE BE LIABLE FOR DIRECT, SPECIAL, INCIDENTAL, CONSEQUENTIAL (INCLUDING LOST PROFIT, OR OTHER DAMAGE, WHETHER BASED IN CONTRACT, TORT, OR OTHERWISE. Some states or counties may not allow the exclusion or limitation of incidental or consequential damages. If you reside in such a state or county, the above limitation or exclusion may not be applicable.

**Do not send your Z-610 back to the service center without return authorization.**

**\*SAVE ORIGINAL SHIPPING BOX**

# Z-610 Manual Juicer Part Description

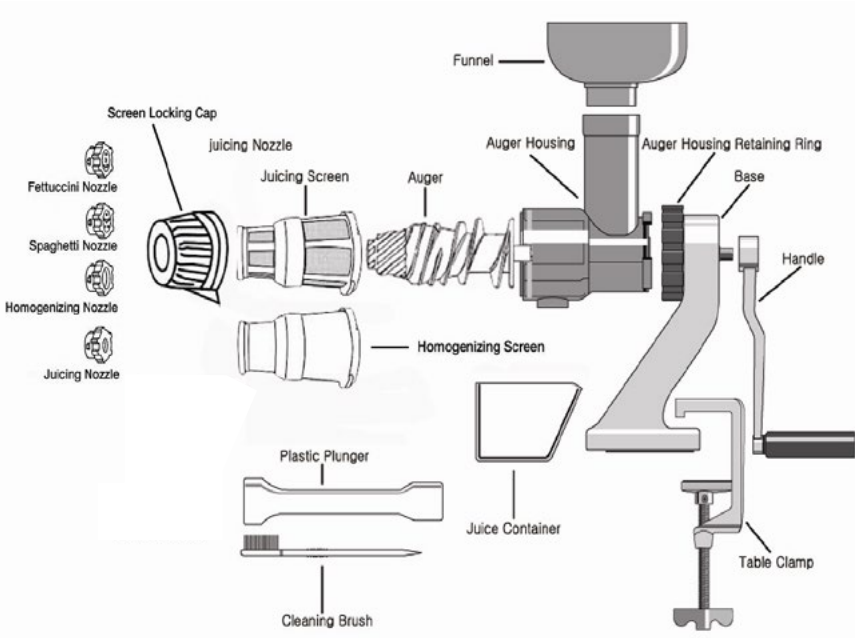

# **—— Z-610 Manual Juicer Assembly and Operation**

1. Place the base of the Z-610 at the edge of a counter or table top.
2. Fit the teeth of the Table Clamp into the groove in the base of the Z-610. Secure the juicer to a counter or table top by tightening the screw.
3. Attach the Handle to the base.
4. Insert the Auger into the Auger Housing and slide the Auger Housing into the Auger Housing Retaining Ring.
5. While holding the Auger Housing stable, turn the Auger Housing Retaining Ring clockwise (right) to lock the Auger Housing in place.
6. Pick the desired screen according to the foods will be juiced and push in.

A. Juicing Screen: for juicing leafy greens, vegetables, and fruits, place the Juicing Screen into the front end of the Auger Housing. Make sure that the side labeled “UP-PER” is facing upwards when inserted. Put the Screen Locking Cap over the screen and turn it counter-clockwise (left) to lock in position. Attach the Juicing Nozzle to the Screen Locking Cap by turning it counter clockwise.

- Fibrous vegetables or fruits with seeds can be juiced by using the Homogenizing Nozzle instead of Juicing Nozzle.
- Small amounts of pulp can be in juices depending on the produce used.

B. Homogenizing Screen: for making Rice Cake/Breadstick, Grinding (tomato, garlic, coffee beans, etc.), Pasta Noodles (Spaghetti or Fettuccini), or Tofu.

- a. Attach the Homogenizing Screen into the Auger Housing. Fasten and turn the Screen Locking Cap counter clockwise to lock in place
- b. Place the desired nozzle into the Screen Locking Cap and turn it counter clockwise.

- Use the Homogenizing Nozzle for homogenizing and grinding fresh garlic, onion, ginger or peppers.
- Do not use the Homogenizing Nozzle for dried pepper, coffee beans etc.

7. Place the Funnel over the Feeding Chute of Auger Housing. Place the Juice Container underneath the specified Juice Outlets.

8. Feed in fruits and vegetables in small amounts into the Funnel as you crank the Handle. Use the Plastic Plunger for assistance in pushing down foods.

- a. Foods need to be cut into smaller lengthwise pieces before juicing.
- b. There may be some normal squeaking noises while operating.

## **Disassembling the Z-610 Manual Juicer** ---

1. Separate the Screen Locking Cap and Nozzle from the unit by turning clockwise.
2. Pull to remove the assembled Screen.
3. Turn the Auger Housing Retaining Ring counter-clockwise to separate from the base.
4. Remove Auger from the Auger Housing.

## **Cleaning the Z-610 Manual Juicer** ---

1. Be sure to clean and properly store the parts of the unit after every operation. When the Screens are not cleaned immediately after every use, the residue can get dried, blocking the holes from filtering and juicing.
2. Use lukewarm water with mild detergent. Do not use hot water or any harsh chemicals such as bleach. It may result to deformation of parts.
3. To remove colored stains, soak parts in 70% White Wine Vinegar and 30% Water.



---

## Troubleshooting

<b>Symptom:</b>	<b>Check to see if:</b>
Loud noise	- the unit is leveled on a flat surface.
Difficulty in feeding foods into the machine	- materials need to be cut into smaller lengthwise pieces.
The Auger Housing does not fit onto the base	- there are any foreign materials inside.
Juice leaks from the back of the Auger Housing	- the Auger Ring is loose and try reassembling. - you have not overloaded the unit; reduce the amount of materials being fed.

# When you need service

---

In the unlikely event that you do need service on your Z-610 Manual Juice Extractor, or if it fails to function properly while within the warranty period (normal household operation only), please contact the nearest authorized Z-610 Service Center. PLEASE FOLLOW THE INSTRUCTIONS BELOW:

## **SERVICE CENTER:**

Tribest Corp. 1143 N. Patt St., Anaheim, CA 92801, USA

Tel: (714) 879-7150, (888) 254-7336 Fax: (714) 879-7140

[service@tribest.com](mailto:service@tribest.com) [www.tribest.com](http://www.tribest.com)

- Call to obtain a return authorization number to send your unit or part back to the service center. Explain the problem you are experiencing.
- Pack your Z-610 or part securely in the original shipping box. Make sure all necessary parts are enclosed. Fill out the Service Request Form below, detach it and enclose it in the shipping box.
- Securely seal the shipping box with strapping tape.
- Address the box to the service center. Be sure to put your return address and the Return Authorization Number on the outside of the package.
- It is always wise to insure the package against possible damages or loss in transit. Ship prepaid.

----- DETACH FORM IN DOTTED LINE -----

## **Service Request Form**

### **1. Customer Information**

First Name: \_\_\_\_\_ Initial: \_\_\_\_\_

Last Name: \_\_\_\_\_

Address: \_\_\_\_\_

City: \_\_\_\_\_ State: \_\_\_\_\_ Zip: \_\_\_\_\_

Phone: \_\_\_\_\_

### **2. Product Information**

Serial #: \_\_\_\_\_ Model #: \_\_\_\_\_

Reason for service request: \_\_\_\_\_

Date of Purchase: \_\_\_\_\_

Place of Purchase: \_\_\_\_\_

Name of parcel/post carrier (in case of damage during delivery): \_\_\_\_\_

---

please  
stamp  
here

## Z-Star Juicer Registration

**TRIBEST CORP.**  
P.O. Box 4089  
Cerritos, CA 90703  
U.S.A.

- Do you have Internet Service?     Yes     No
- Have you ever purchased any products through Internet Stores?     Yes     No
- Do you use e-mail at work?     Yes     No  
  email Address: \_\_\_\_\_
- Do you use e-mail at home?     Yes     No  
  email Address: \_\_\_\_\_
- Please check all that apply to your household
  - Regularly Purchase Items Through the Mail
  - Member of Frequent Flyer Program
  - Subscribe to Cable or Satellite TV
  - Have a CD Player
  - Have a DVD Player
  - Use a Personal Computer
  - Military Veteran in Household
  - Support Health Charities
  - Have a Microwave Oven
  - Have a VCR
  - Have a DVR

Thank you for taking the time to fill out this questionnaire. Your answers will be used to help us better serve you in the future. Periodically, we would like to send you important product information and special offers. Be assured, your privacy is important to us and your information is never shared or sold to third parties unless it is required for us to conduct regular business with you, or unless it is required by law. Please initial here if you would not like us to send you important product updates and announcements:

\_\_\_\_\_  
If you have comments or suggestions about our product, please write to:  
Z-Star Customer Relations, P.O. Box 4089, Cerritos, CA 90703

# Z-STAR REGISTRATION FORM

**PLEASE FILL OUT AND RETURN WITHIN THE NEXT 10 DAYS** Please write all information legibly!

**1. Customer Information**

Mr.     Mrs.     Ms.     Miss

First Name \_\_\_\_\_ Initial \_\_\_\_\_ Last Name \_\_\_\_\_

Street \_\_\_\_\_ Apt. No. \_\_\_\_\_

City \_\_\_\_\_ State \_\_\_\_\_ Zip \_\_\_\_\_

Phone \_\_\_\_\_ Email Address \_\_\_\_\_

**2. Date of Purchase:** Month \_\_\_\_\_ Day \_\_\_\_\_ Year \_\_\_\_\_

**3. Product Information:**

Z-Star Model #: \_\_\_\_\_ Serial #: \_\_\_\_\_

**4. Dealer Information**

Dealer Name \_\_\_\_\_

Dealer Address \_\_\_\_\_

Phone \_\_\_\_\_

**OPTIONAL SURVEY**

• How did you learn of Z-Star? (Please check only one.)

- |   |  |   |
|---|--|---|
| <input type="checkbox"/> Received as a gift           | <input type="checkbox"/> Magazine advertisement  | <input type="checkbox"/> Newspaper advertisement  |
| <input type="checkbox"/> TV advertisement             | <input type="checkbox"/> Radio advertisement     | <input type="checkbox"/> In-store display or demo |
| <input type="checkbox"/> Consumer magazine article    | <input type="checkbox"/> Friend's recommendation | <input type="checkbox"/> Salesperson              |
| <input type="checkbox"/> Information through the mail | <input type="checkbox"/> Other                   |   |

• What is your primary residence?

- |  |   |                                       |
|--|---|---------------------------------------|
| <input type="checkbox"/> Own a House                                 | <input type="checkbox"/> Own a Townhouse or Condo | <input type="checkbox"/> Rent a House |
| <input type="checkbox"/> Rent an Apartment, Townhouse or Condominium |   |                                       |

• What is your Annual Household Income?

- |   |   |  |
|---|---|--|
| <input type="checkbox"/> Less than \$15,000 | <input type="checkbox"/> \$15,000-\$25,000  | <input type="checkbox"/> \$25,000-\$50,000   |
| <input type="checkbox"/> \$50,000-\$75,000  | <input type="checkbox"/> \$75,000-\$100,000 | <input type="checkbox"/> more than \$100,000 |

• What factors most influenced your decision to purchase this juicer? (please check up to three)

- |   |  |   |
|---|--|---|
| <input type="checkbox"/> Z-Star reputation        | <input type="checkbox"/> Style and appearance  | <input type="checkbox"/> Value for the price  |
| <input type="checkbox"/> Special product features | <input type="checkbox"/> Warranty  | <input type="checkbox"/> Rebate or sale price |
| <input type="checkbox"/> Quality and durability   | <input type="checkbox"/> Consumer Magazine Article <input type="checkbox"/> Reputation of the Dealer |   |
| <input type="checkbox"/> Friend Recommendation    | <input type="checkbox"/> Salesperson   | <input type="checkbox"/> Other                |

• What is your occupation?

- |   |   |  |
|---|---|--|
| <input type="checkbox"/> Homemaker                          | <input type="checkbox"/> Professional/Technical | <input type="checkbox"/> Upper Management or Executive |
| <input type="checkbox"/> Middle Management                  | <input type="checkbox"/> Sales/Marketing        | <input type="checkbox"/> Clerical or Service Worker    |
| <input type="checkbox"/> Self Employed/Business Owner       | <input type="checkbox"/> Student                | <input type="checkbox"/> Retired                       |
| <input type="checkbox"/> Tradesman/Machine Operator/Laborer |   |  |

• Which credit cards do you use regularly?

- |   |  |   |
|---|--|---|
| <input type="checkbox"/> Visa                   | <input type="checkbox"/> MasterCard              | <input type="checkbox"/> American Express |
| <input type="checkbox"/> Discover               | <input type="checkbox"/> Department Store        | <input type="checkbox"/> Diner's Club     |
| <input type="checkbox"/> Gasoline Company, etc. | <input type="checkbox"/> Do not use credit cards |   |

---

## Product Specifications

<b>ITEM</b>	Z-Star Manual Vegetable and Fruit Juicer
<b>MODEL</b>	Z-610
<b>SIZE</b>	13.2in (335mm) x12.6in (320mm) x 4.9in (125mm)
<b>WEIGHT</b>	6.8lbs (3.1kg)



Tribest Corporation  
P.O. Box 4089, Cerritos, CA 90703  
Toll Free: (888) 254-7336  
service@tribest.com | www.tribest.com